



NANO QUAD



FUNFLYER³ by **ADVENTURE**

Funflyer[®]3 the renewal
of a best seller

Flying has never
been so easy!



15 years experience with the Funflyer, single seater and tandem trike, has enabled Adventure Paramotor to design the brand new Funflyer[®]3.

FUNFLYER 3



Optimized BALANCE between center of gravity, glider anchors and wheels' suspension



Robust

Made in stainless steel, steel and carbon fiber, the FunFlyer3 has a reinforced structure designed on a heavy duty tandem basis version, with minimum weight.

Efficient

Its chassis geometry is designed for better wing inflating and better ground acceleration, for short and safety take off. It is also more ergonomic for both single seater and tandem pilotage.

Comfortable

Pilot and passenger positions have been revised with better geometry and seating quality.

Aluminum wheels



Plastic wheels



Parachute



ADVENTURE 
PARAMOTORS

Robust
Efficient
Comfortable

FUNFLYER³



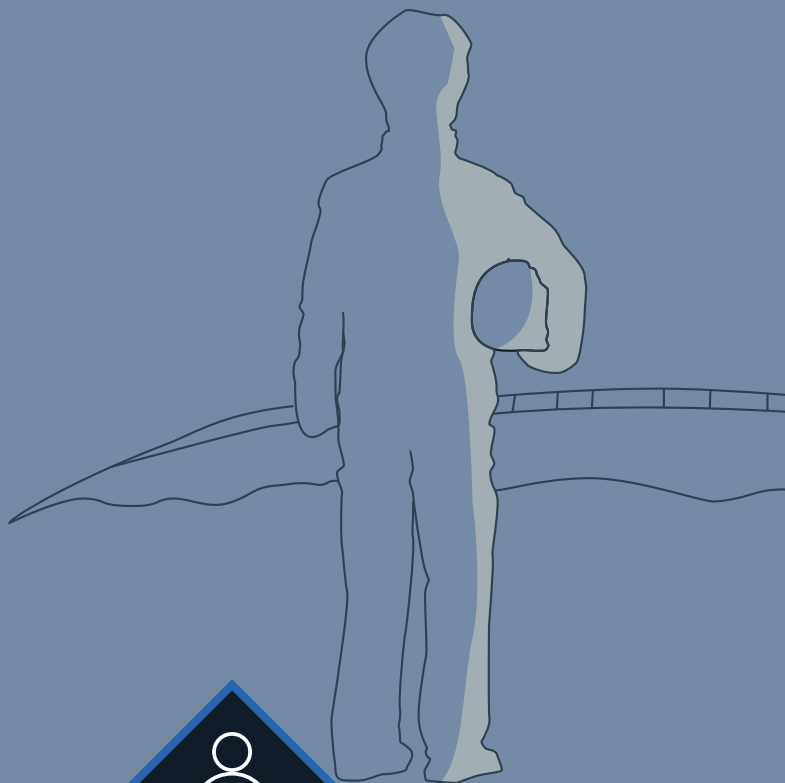

Nano Quad chassis



<u>Width</u>	1m41
<u>Length (ext wheels)</u>	1m34
<u>Wheels F/R</u>	260mm/300mm
<u>Weight</u>	19kg
<u>Feet positions</u>	4
<u>Seat positions</u>	3
<u>Modes</u> : beginner or expert	

Engines on Pluma



Atom 80

Moster 185



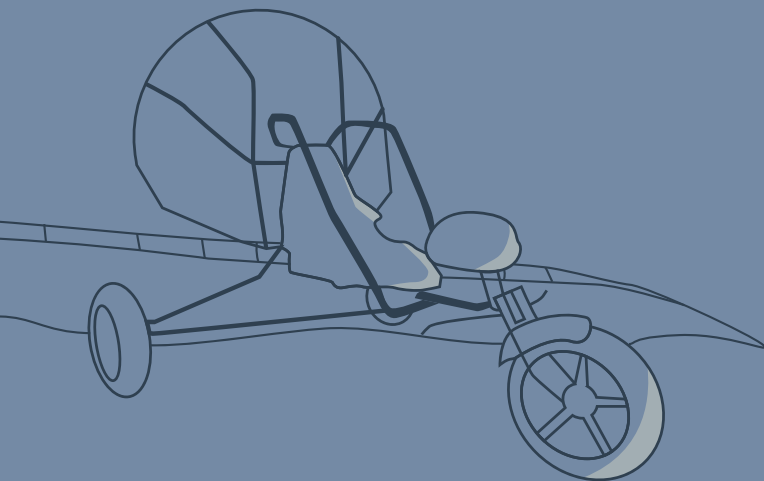

Funflyer 3 chassis



Engines



Cosmos 300 Thor 303

<u>Width</u>		1m68
<u>Height (total)</u>		1m95
<u>Height (w/o cage)</u>		1m21
<u>Length (total)</u>		2m32
<u>Length (ext wheels)</u>		2m11
<u>Cage diameter</u>		1m84
<u>Wheels</u>	standard	400mm
<u>Weight</u>	version	88/85kg
<u>Wheels</u>	aluminum	10"
<u>Weight</u>	version	90/87kg

<u>TType</u>	2 stroke	2 stroke
<u>Cc</u>	300cc	303cc
<u>Power</u>	37hp	37hp
<u>Mixture</u>	Yes	Yes
<u>Clutch</u>	Yes	Yes
<u>Reduction</u>	1 / 3,04	1 / 3.2
<u>Starter</u>	DUAL	DUAL
<u>Battery</u>	12V Pb	12V Pb
<u>Gas tank</u>	23L	23L
<u>Propeller</u>	3blade 1m60	3blade 1m60
<u>Thrust</u>	125kg	120kg
<u>Autonomy</u>	3h	3h

Chassis	Stell and stainless steel
Safety belt	4 points Sparco
Foam	10cm foam, removable & washable honeycomb cover

Tandem trike

Funflyer 3 is available with the famous **THOR 303** and **COSMOS300** engines from Polini and Vittorazi.

Both engines power our two-seater trike with a 160 cm three-bladed propeller for a more powerful and quieter machine.

The steel chassis is ready to equip optional pneumatic rescue for **maximum safety**.



Single seater

To replace the Funflyer single seater, a **Nano trike** has been studied and now finalized in 4 wheels configuration with a fully articulated front and rear axles both connected with a steering bar (**DRIFT system**).

Compatible with **PLUMA** only, this trike is clearly a small revolution in the world of the light trikes by its stability and its maneuverability! It will open up new horizons in practice and steering improvement.

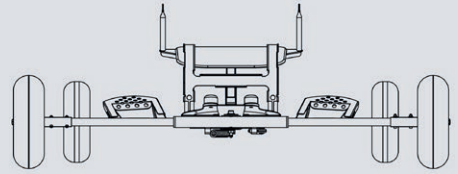
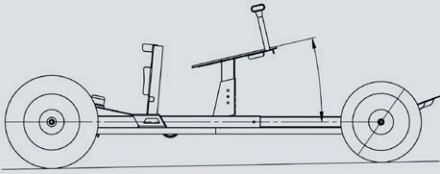

NANO QUAD

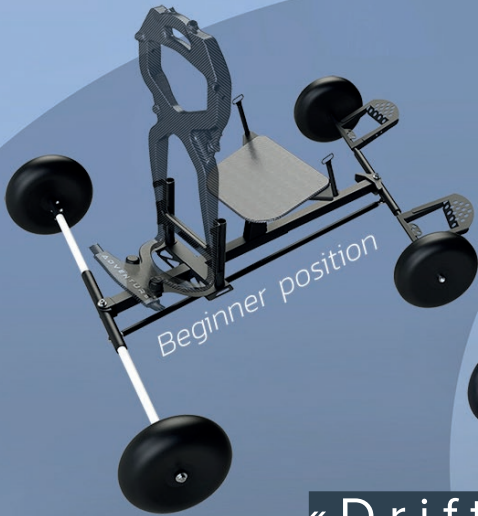
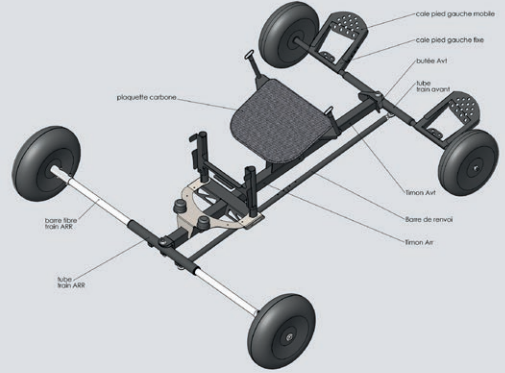
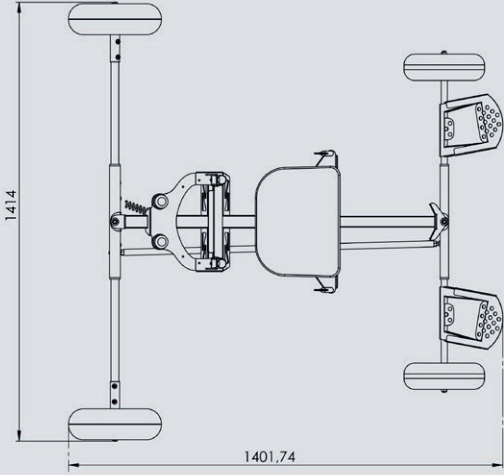

NANO QUAD



« Drift »
System
Handy



ADVENTURE 
PARAMOTORS

36 Rue des Osiers – Lot 9 – 78310 Coignières
tél: 01.34.57.00.00 fax: 01.34.57.00.99
e-mail: info@adventure.fr
www.adventure.fr



2021/10/01